

REVISIONS			
REV	DESCRIPTION	DATE	APPROVED

This document contains the proprietary information of Tandemloc, Inc. and your access and use shall be, and is at all times, pursuant to and limited by the Tandemloc, Inc. Terms of Use. You shall not, and shall not encourage, assist, or authorize another party to copy, distribute, publicly display, modify, reverse engineer, decompile, or take any other action to reproduce this document or the information contained herein.

©2019 by Tandemloc, Inc.
Dimensions are subject to manufacturing tolerance and change.

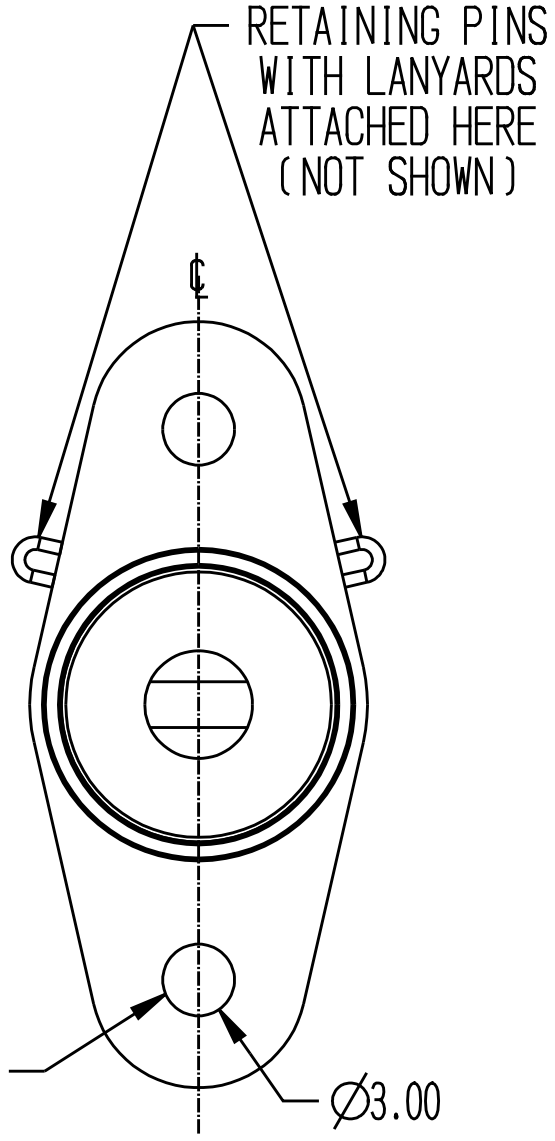
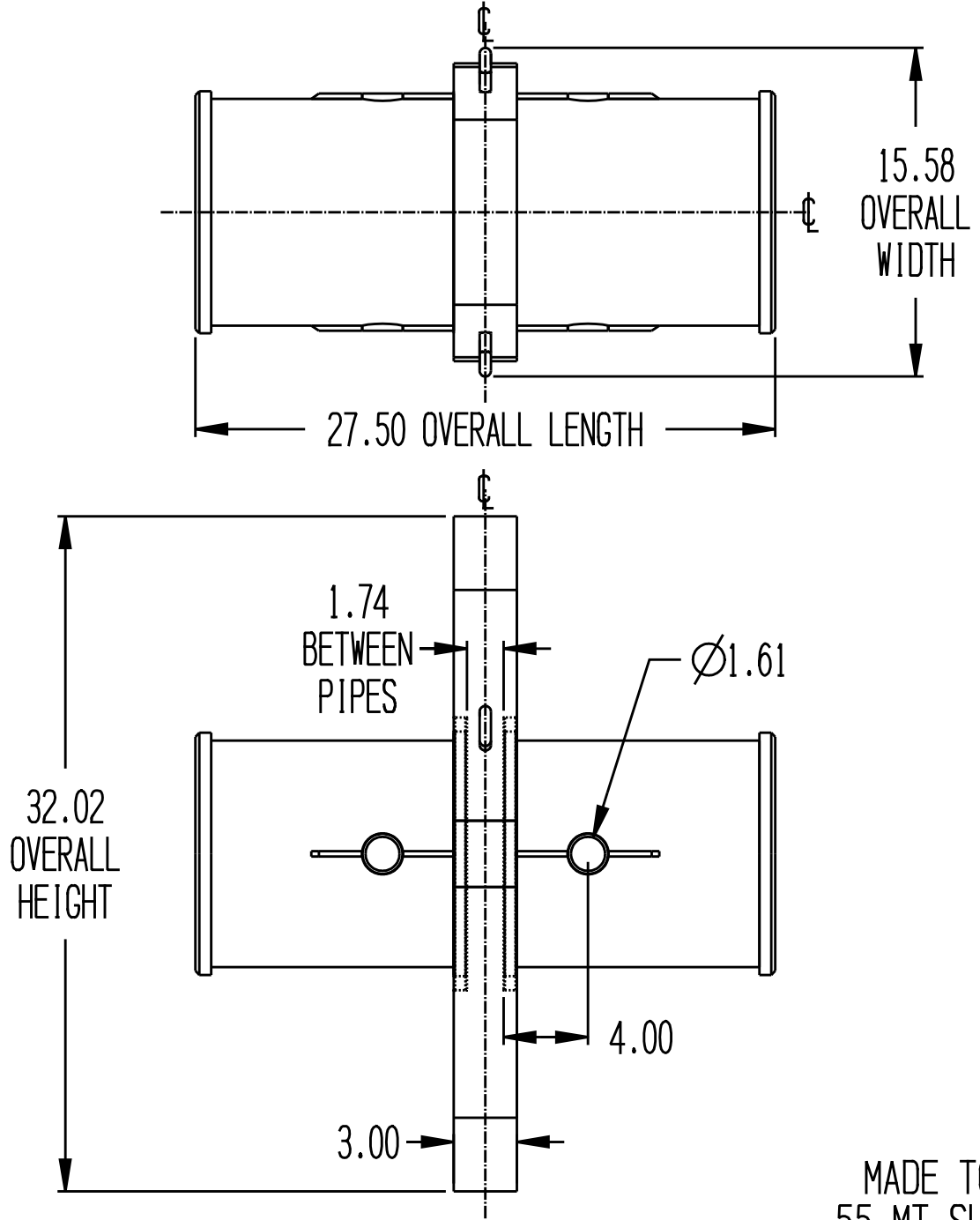

MADE TO FIT 55 MT SHACKLES

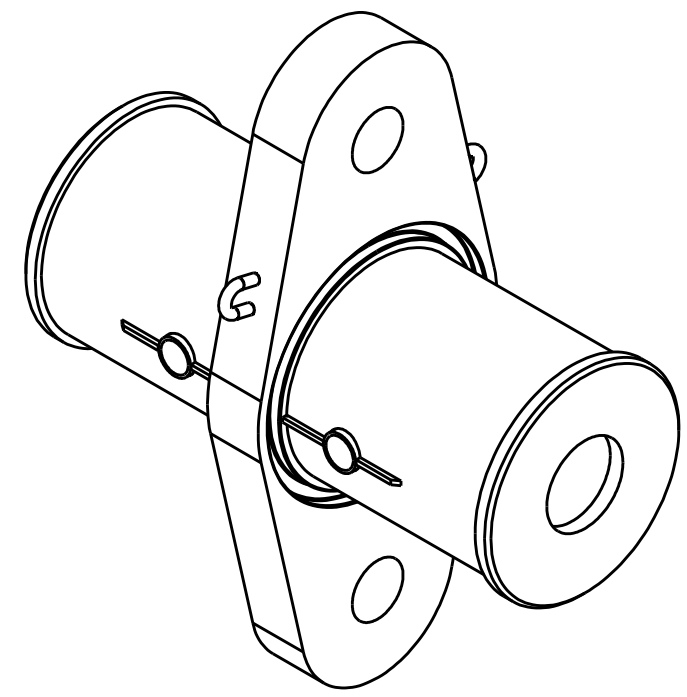

- NOTES:
- PART NO.: AG08ALP-12X, 12" PIPE SLEEVE WITH CENTER LIFT
 - WLL: 130,000 LB. STRAIGHT PULL
 - PROOF TESTED TO 125% (162,500 LB.) AND CERTIFIED
 - STANDARD SPECIFICATION # EAD21000A APPLIES
 - FINISH: SANDBLAST, PRIME AND PAINT SAFETY YELLOW
 - CALCULATED WEIGHT: 415 LB.
 - DESIGNED AND MANUFACTURED TO MEET OR EXCEED ASME B30.20 AND BTH-1, DESIGN CATEGORY B, SERVICE CLASS 0.
 - DOES NOT ADD CAPACITY TO EXISTING SPREADER ASSEMBLY. TOTAL MAX CAPACITY FOR LIFT IS STILL LIMITED TO PUBLISHED END CAP CAPACITY/OR SPAN FOR GIVEN ASSEMBLY. SEE PUBLISHED CHART OR END CAP APP @ TANDEMLOC.COM
 - NOT TO BE USED WITHOUT TOP SLING
 - VERTICAL PICK ONLY

** DO NOT SIGN IF CHANGES ARE REQUIRED **

CUSTOMER APPROVAL: _____

DATE: _____

<small>XX</small> *X DENOTES APPLICABLE DATA UNLESS OTHERWISE NOTED, DIMENSIONS ARE IN INCHES & TOLERANCES ARE: .XX ±.06 .XXX ±.0007 .XXX ±.03	<small>X</small> *X DENOTES APPLICABLE DATA LOST WAX CASTING TOL. IS: 0 TO 4" ±.030 , 4.01" TO 7" ±.038" 7.01" TO 10.5" ±.045" OVER 10.5" ±.052"	TANDEMLOC	
		TITLE AG08ALP-12X 12" PIPE SLEEVE WITH CENTER LIFT	
<small>THIS DOCUMENT CONTAINS DATA WHICH IS EITHER PATENTED, PATENT PENDING OR IS THE PROPERTY OF TANDEMLOC, INC. DISCLOSURE, OR COPYING WITHOUT THE WRITTEN AUTHORIZATION OF TANDEMLOC, INC. IS EXPRESSLY PROHIBITED.</small>	APPROVALS DRAWN DAH 11-24-20 ENGINEER WDD 11-24-20	DATE 11-24-20	SIZE D CAGE CODE 65059 DWG NO. SAG08ALP-12X REV. -
SCALE			SHEET 1 OF 1