

CONTAINER CART - 16,000 LB CAPACITY (T10000C-4PA)

Cage Code: 65059 | Drawing No: ST10000C-4PA | Revision: D | Sheet: 1 of 1

UNLESS OTHERWISE SPECIFIED, DIMENSIONS ARE IN INCHES
DO NOT SCALE DRAWING

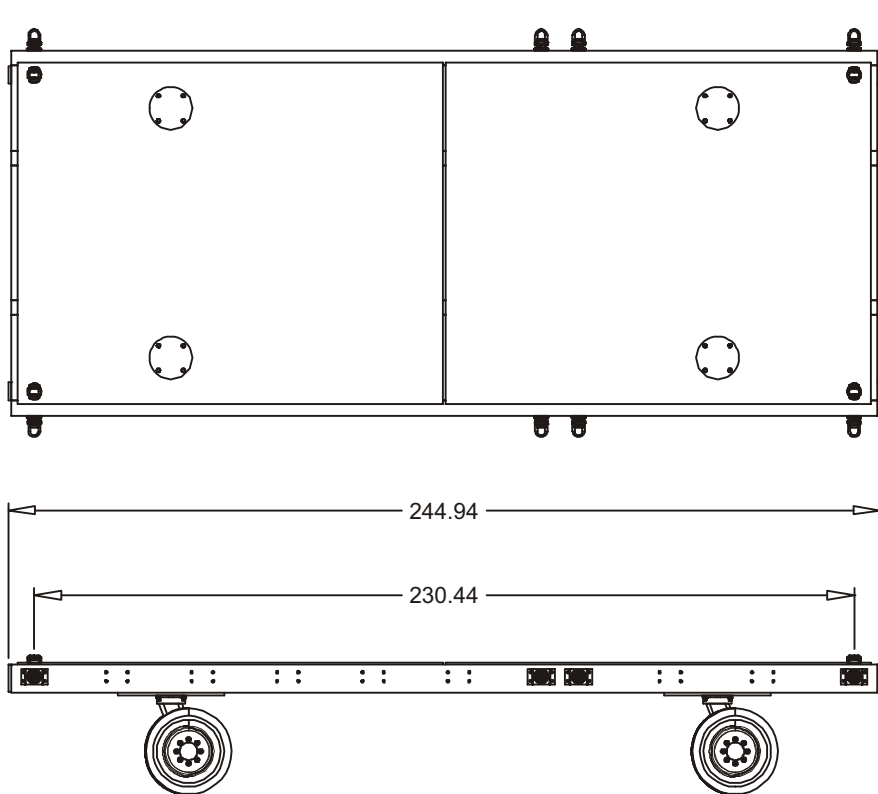

OPTIONAL TANDEMLOC TOWBAR
P/N: AB42000A-2PA. USE
AT EITHER END TO TOW UNIT

NOTE:

1. P/N: T10000C-4PA, CONTAINER CART, 20'12", 16,000 LB CAPACITY
2. WLL: 8T (16,000 LB)
3. STANDARD SPECIFICATION # EAD2100A APPLIES
4. FINISH: (STD) SANDBLASTED, PRIMED AND PAINTED SAFETY YELLOW
5. CALCULATED WEIGHT: 7,000 LBS (INCLUDES CASTERS)

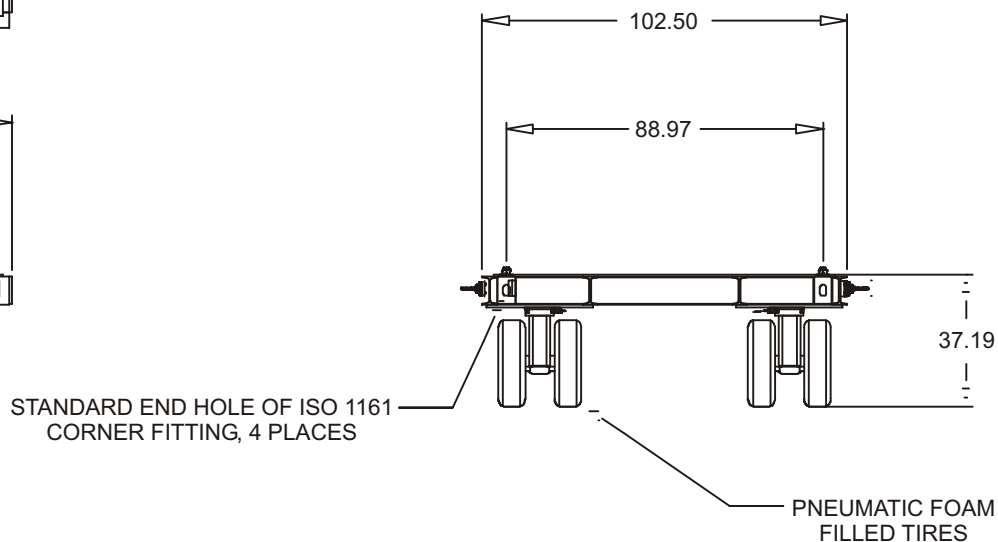

DANGER: Never Exceed WLL (Working Load Limit)

This document contains data which is either patented, patent pending or is the property of Tandemloc, Inc.

Disclosure, or copying without the written authorization of Tandemloc, Inc. is expressly prohibited. © Copyright 2002 by Tandemloc, Inc.

DWG Files are available for engineering application - contact Tandemloc for details. Dimensions are subject to manufacturing tolerance and change.

REV	DESCRIPTION	REVISIONS	DATE	APPROVED
B	MADE TOWBAR OPTIONAL, NO LONGER SHOWN		04/28/06	BT
C	WLL WAS 67,200 LB. ON -2PA AND -3PA		12/13/07	DAH
D	OPTIONAL TOWBAR WAS A -1PA AND NOW IS A -2PA		12/4/08	DAH



Email: info@tandemloc.com • www.tandemloc.com
PO Box 279 • 824 Highway 101 • Havelock, NC 28532-0279
TEL: 1.800.258.7324 (252.447.7155)
FAX: 1.800.892.3273 (252.447.5502)

Tandemloc designs, manufactures and tests lifting, securing and mobilizing components for all industries. See our website for details and important safety information.

Tandemloc is a member of:

