

ISO CONTAINER CART - 20'; 30 LT W/ FF PNEUMATIC CASTERS (T10000C-3PA)

Cage Code: 65059 | Drawing No: ST10000C-3PA | Revision: D | Sheet: 1 of 1

UNLESS OTHERWISE SPECIFIED, DIMENSIONS ARE IN INCHES
DO NOT SCALE DRAWING

NOTE:

1. P/N: T10000C-3PA, ISO CONTAINER CART - 20', 60,000 LB CAPACITY
T10000C-3PAFFT, CART WITH FOAM FILLED PNEUMATIC TIRES
2. WLL: 30 TON (60,000 LB)
3. FINISH: SANDBLASTED, PRIMED AND PAINTED SAFETY YELLOW
4. CALCULATED WEIGHT: 3,380 (INCLUDES CASTERS)

OPTIONAL TANDEMLOC TOWBAR
P/N: AB42000A-2PA. USE AT EITHER END
TO TOW UNIT

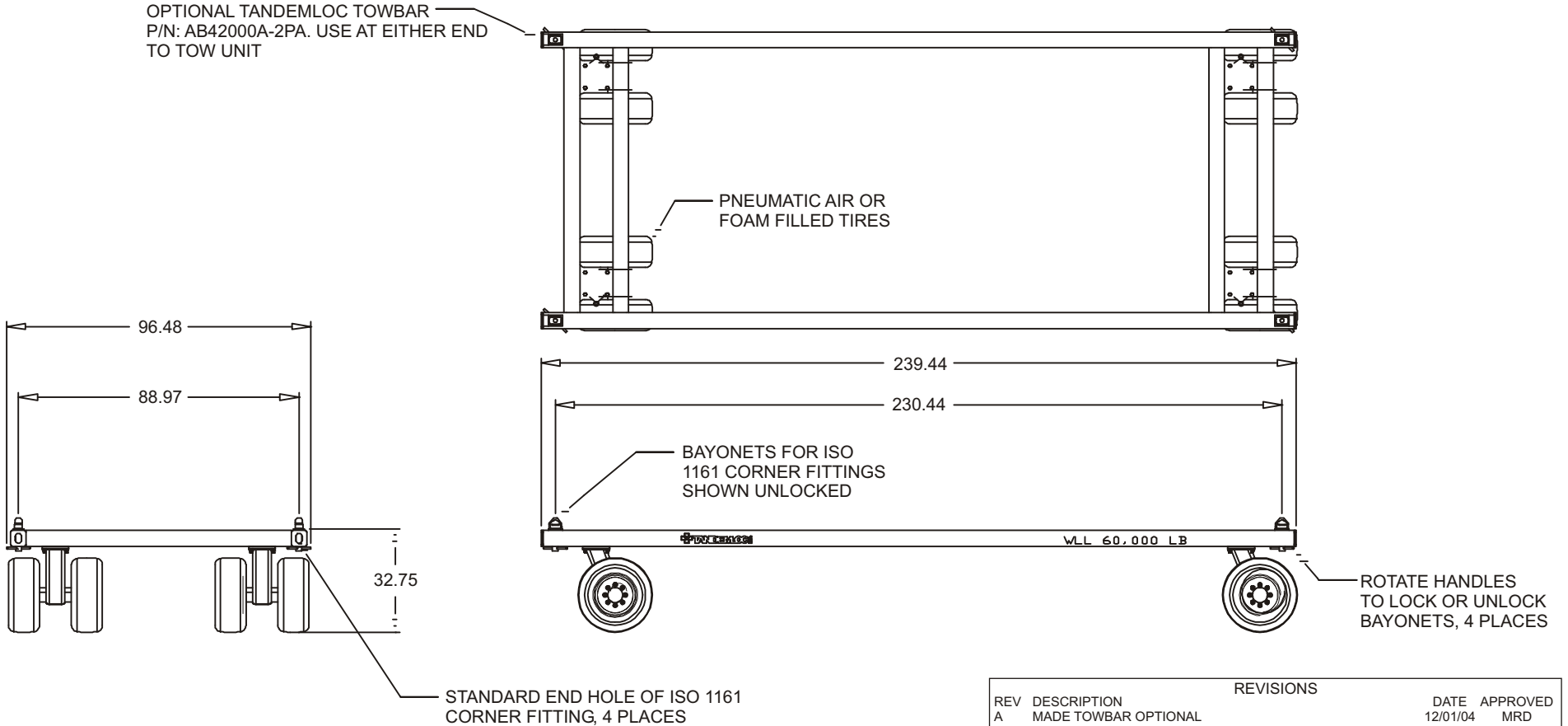

REV	DESCRIPTION	REVISIONS	DATE	APPROVED
A	MADE TOWBAR OPTIONAL		12/01/04	MRD
B	MADE TOWBAR OPTIONAL, NO LONGER SHOWN		04/28/06	BT
C	WLL WAS 67,200 LB. ON -2PA AND -3PA		12/13/07	DAH
D	OPTIONAL TOWBAR WAS A -1PA AND NOW IS A -2PA		12/4/08	DAH

To avoid lifter failure, potential death and property damage, never exceed WLL (Working Load Limit)

This document contains the proprietary information of Tandemloc, Inc. and your access and use shall be, and is at all times, pursuant to and limited by the Tandemloc, Inc. Terms of Use.

You shall not, and shall not encourage, assist, or authorize another party to copy, distribute, publically display, modify, reverse engineer, decompile, or take any other action to reproduce or replicate this document or the information contained herein. © Copyright 2012 by Tandemloc, Inc.

Dimensions are subject to manufacturing tolerance and change.



Email: info@tandemloc.com • www.tandemloc.com
824 Highway 101 • Havelock, NC 28532
TEL: 1.800.258.7324 (252.447.7155)
FAX: 1.800.892.3273 (252.447.5502)

Tandemloc designs, manufactures and tests lifting, securing and mobilizing components for all industries. See our website for details and important safety information.

Read all safety labels and instructions prior to use. Product to be used by qualified personnel only.