

# TWO CRANE LIFT BEAM (Q0100AA-1PA)

Cage Code: 65059 | Drawing No: SQ0100AA | Revision: -- | Sheet: 1 of 1

UNLESS OTHERWISE SPECIFIED, DIMENSIONS ARE IN INCHES  
DO NOT SCALE DRAWING

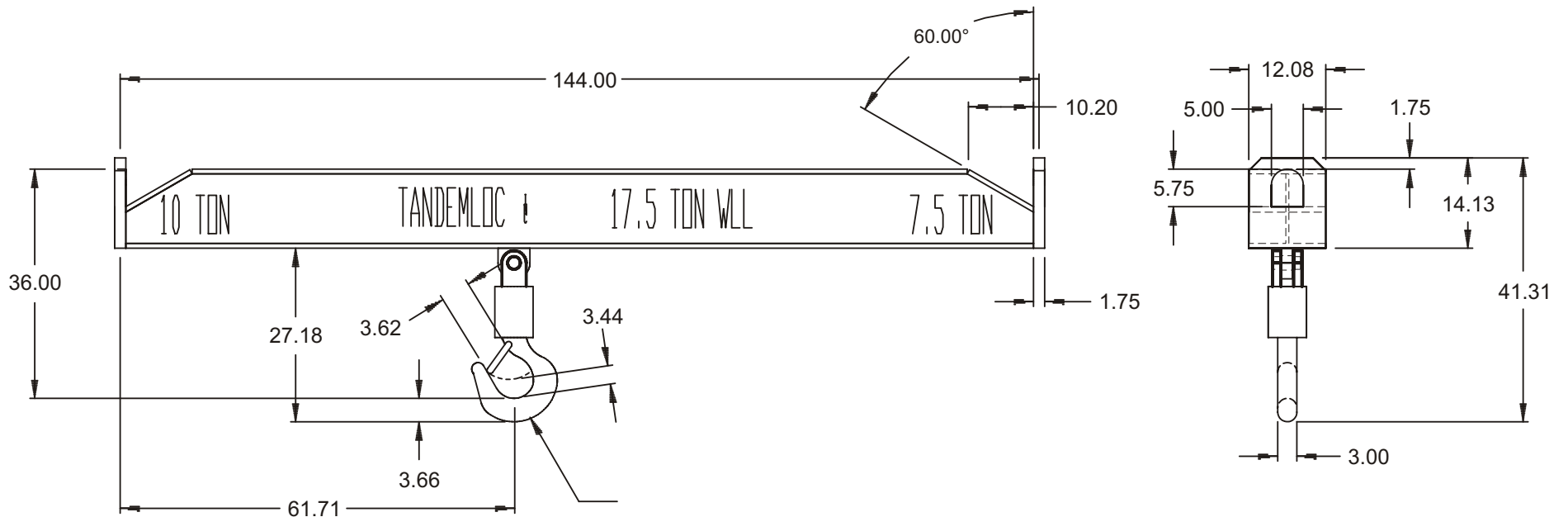

P/N: Q0100AA-1PA TWO CRANE LIFT BEAM  
FINISH: SAFETY YELLOW PAINT  
WLL: 17.5 TON (35000 LB)  
WEIGHT: 1225 LBS (CALCULATED)  
PROOF TEST: 2 X SWL (70000 LB)

To avoid lifter failure, potential death and property damage, never exceed WLL (Working Load Limit)

This document contains the proprietary information of Tandemloc, Inc. and your access and use shall be, and is at all times, pursuant to and limited by the Tandemloc, Inc. Terms of Use.

You shall not, and shall not encourage, assist, or authorize another party to copy, distribute, publically display, modify, reverse engineer, decompile, or take any other action to reproduce or replicate this document or the information contained herein. © Copyright 2012 by Tandemloc, Inc.

Dimensions are subject to manufacturing tolerance and change.



Email: [info@tandemloc.com](mailto:info@tandemloc.com) • [www.tandemloc.com](http://www.tandemloc.com)  
824 Highway 101 • Havelock, NC 28532  
TEL: 1.800.258.7324 (252.447.7155)  
FAX: 1.800.892.3273 (252.447.5502)

Tandemloc designs, manufactures and tests lifting, securing and mobilizing components for all industries. See our website for details and important safety information.  
Read all safety labels and instructions prior to use. Product to be used by qualified personnel only.