

FASTMOUNTS WITH & WITHOUT BASE PLATES (N2501BA)

Cage Code: 65059 | Drawing No: SN2501BA | Revision: AC | Sheet: 1 of 1

UNLESS OTHERWISE SPECIFIED, DIMENSIONS ARE IN INCHES

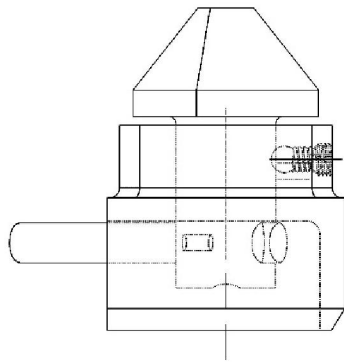
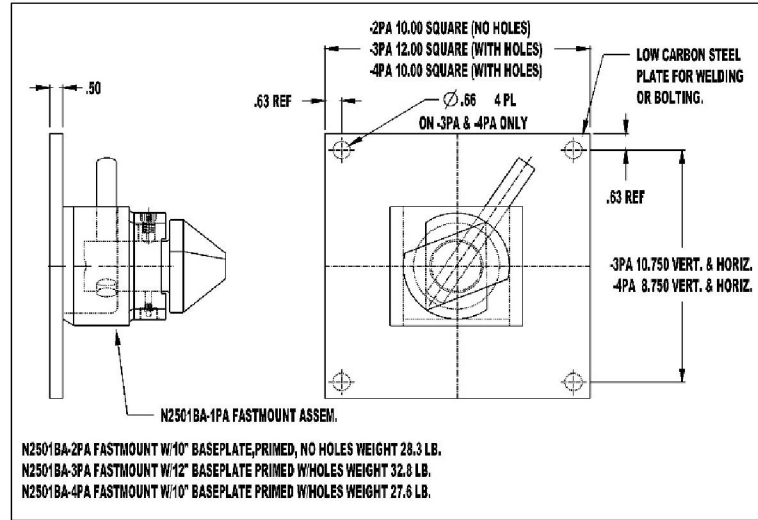
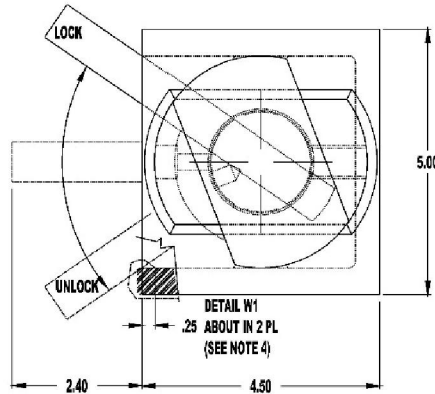

N2501BA-1PA FASTMOUNT, PRIMED COAT PAINTED WEIGHT 13.9 LB.

NOTE:

- MATERIAL: STEEL, PAINT PRIMER COAT.
- STRENGTH RATINGS AT YIELD POINT -
UPWARD RESTRAINT - 51,000 LB. (TENSILE)
COMPRESSION - 201,000 LB. (ON BODY)
TRANSVERSE SHEAR - 76,000 LB.
LONGITUDINAL SHEAR - 40,000 LB.
- CAUTION NOT FOR ATTACHING CASTER WHEELS TO CONTAINERS. USE N25000C-2GA CASTER LOCKS WHICH HAVE TIGHTENING FEATURES.
- CAST HOUSING MATERIAL IS EQUAL TO ASTM A27 GR. 70-40. IF GMAW WELDING TO ASTM A36 STEEL, LINCOLN FILLER WIRE MC-710XL WITH SHIELDING GAS AS REQUIRED BY AWS CLASSIFICATION MAY BE USED. ALSO SEE DETAIL W1 & W2.

To avoid lifter failure, potential death and property damage, never exceed WLL (Working Load Limit).

This document contains the proprietary information of Tandemloc, Inc. and your access and use shall be, and is at all times, pursuant to and limited by the Tandemloc, Inc. Terms of Use.

You shall not, and shall not encourage, assist, or authorize another party to copy, distribute, publicly display, modify, reverse engineer, decompile, or take any other action to reproduce this document or the information contained herein. © Copyright 2014 by Tandemloc, Inc.

Dimensions are subject to manufacturing tolerance and change.



Email: info@tandemloc.com • www.tandemloc.com

824 Highway 101 • Havelock, NC 28532

Tel: 1.800.258.7324 (252.447.7155)

FAX 1.800.892.3273 (252.447.5502)

Tandemloc, Inc. designs, manufactures and tests lifting, securing and mobilizing components for all industries. See our website for details and important safety information.

Read all safety labels and instructions prior to use. Product to be used by qualified personnel only.