

FOUR POINT ADJUSTABLE SPREADER (AD47000A-1PA)

Cage Code: 65059 | Drawing No: SAD47000A | Revision: A | Sheet: 1 of 1

UNLESS OTHERWISE SPECIFIED, DIMENSIONS ARE IN INCHES
DO NOT SCALE DRAWING

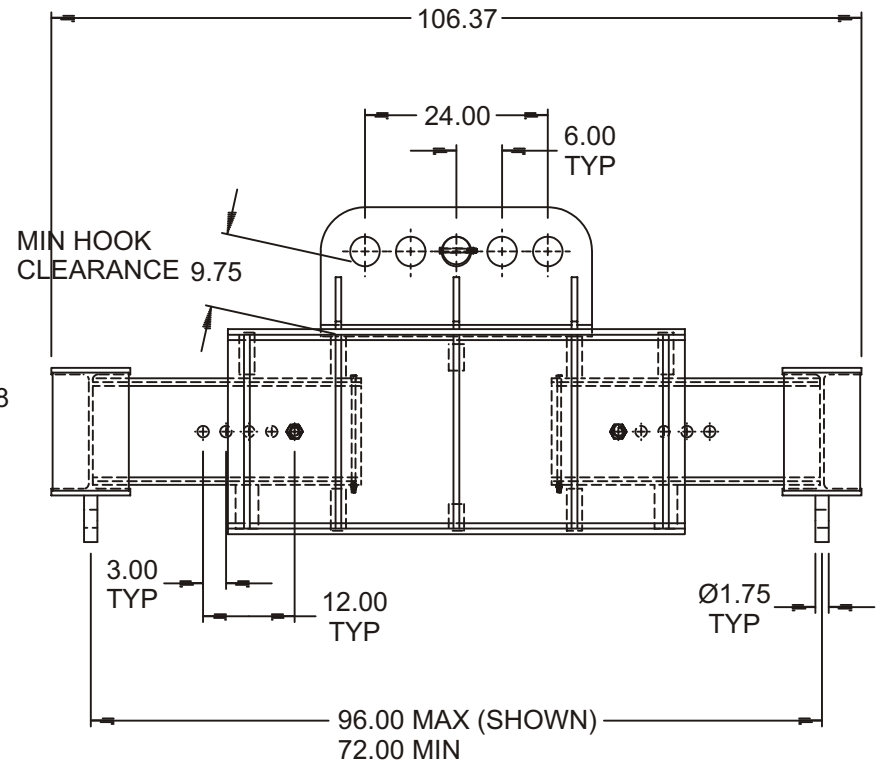
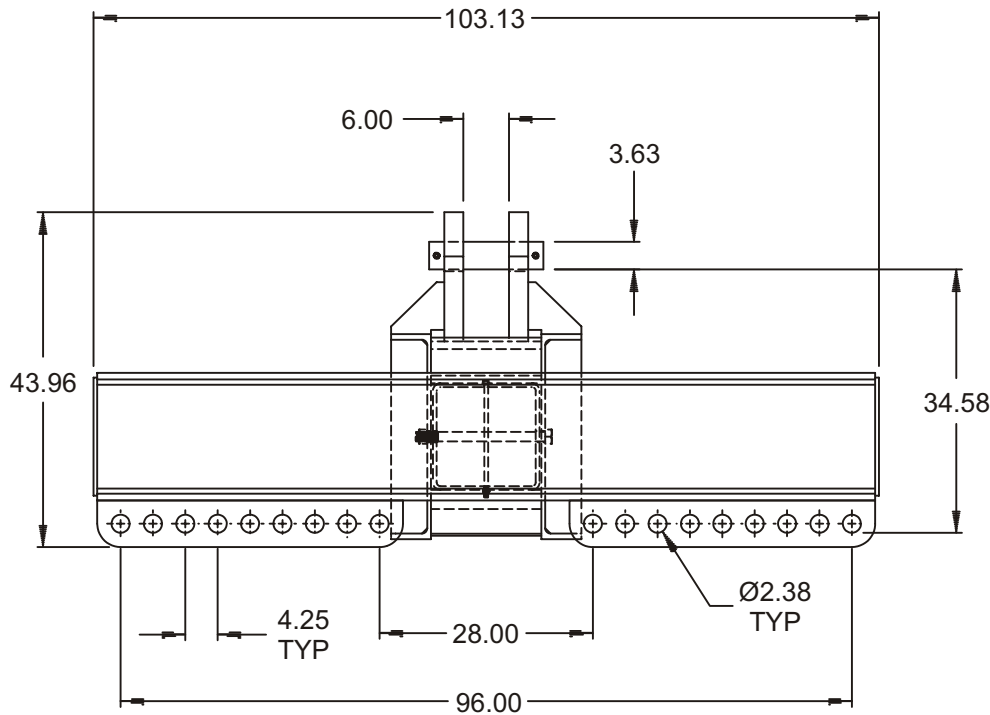

NOTE:

1. P/N: AD47000A-1PA, FOUR POINT ADJUSTABLE SPREADER
2. WLL: 125,000 LB
3. PROOF TESTED TO 125% (156,250 LB) AND CERTIFIED
4. DESIGNED AND MANUFACTURED TO MEET OR EXCEED ASME B30.20
5. FINISH: SANDBLAST, PRIME AND PAINT SAFETY YELLOW
6. CALCULATED WEIGHT: 4,875 LB

REVISIONS		
REV	DESCRIPTION	DATE APPROVED
A	REVISED PER CUSTOMER REQUIREMENTS	11/03/03 W.D.D.

To avoid lifter failure, potential death and property damage, never exceed WLL (Working Load Limit)

This document contains the proprietary information of Tandemloc, Inc. and your access and use shall be, and is at all times, pursuant to and limited by the Tandemloc, Inc. Terms of Use.

You shall not, and shall not encourage, assist, or authorize another party to copy, distribute, publically display, modify, reverse engineer, decompile, or take any other action to reproduce or replicate this document or the information contained herein. © Copyright 2012 by Tandemloc, Inc.

Dimensions are subject to manufacturing tolerance and change.



Email: info@tandemloc.com • www.tandemloc.com
824 Highway 101 • Havelock, NC 28532
TEL: 1.800.258.7324 (252.447.7155)
FAX: 1.800.892.3273 (252.447.5502)

Tandemloc designs, manufactures and tests lifting, securing and mobilizing components for all industries. See our website for details and important safety information.
Read all safety labels and instructions prior to use. Product to be used by qualified personnel only.