

NOTES:

1. PART NO.: AA60000A-4PA
2. WLL: 5 TON (10,000 LB.)
3. PROOF TESTED TO 125% (12,500 LB.) AND CERTIFIED
4. STANDARD SPECIFICATION #EAD21000A APPLIES
5. FINISH: SANDBLAST, PRIME AND PAINT SAFETY YELLOW
6. CALCULATED WEIGHT: 245 LB.
7. DESIGNED AND MANUFACTURED TO MEET OR EXCEED ASME B30.20 AND BTH-1, DESIGN CATEGORY B, SERVICE CLASS 0.

# FOUR POINT ADJUSTABLE SPREADER (AA60000A-4PA)

Cage Code: 65059 | Drawing No: SAA60000A | Revision: A | Sheet: 1 of 1

UNLESS OTHERWISE SPECIFIED, DIMENSIONS ARE IN INCHES  
DO NOT SCALE DRAWING

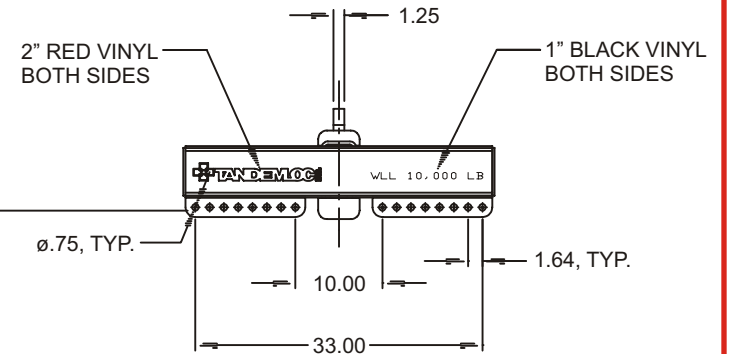
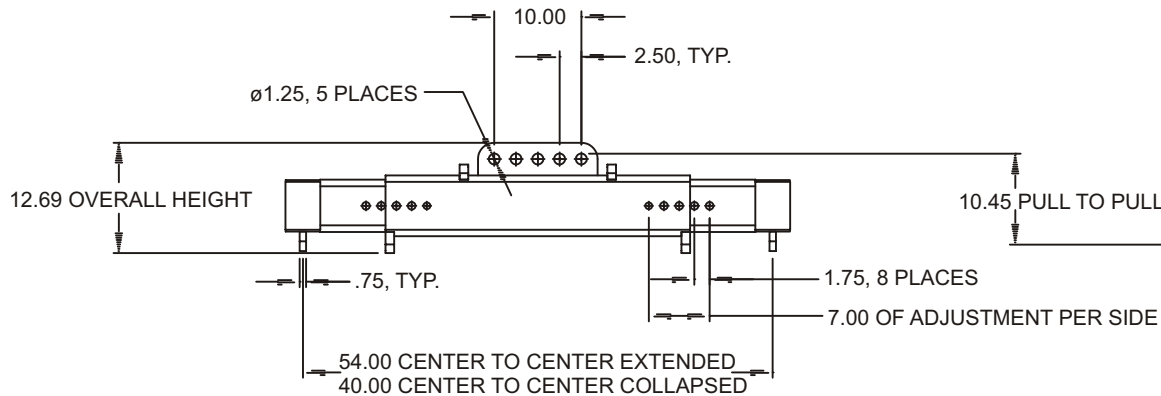
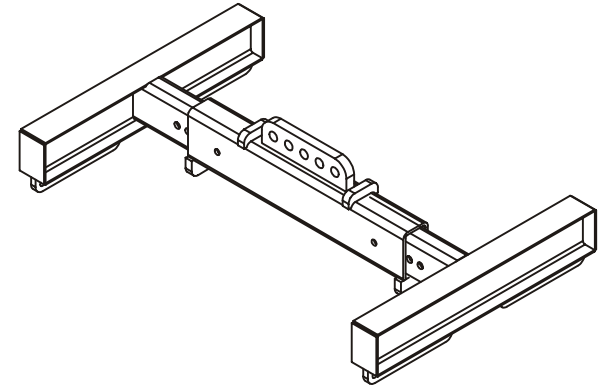
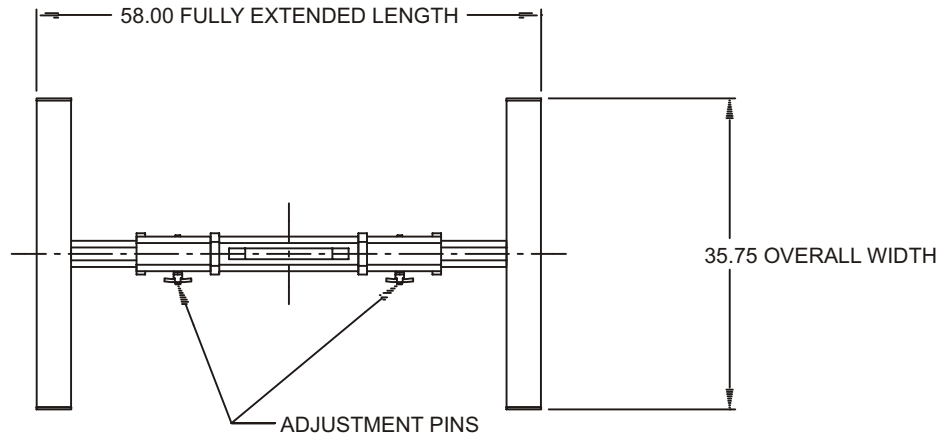

**DANGER: Never Exceed WLL (Working Load Limit)**

This document contains data which is either patented, patent pending or is the property of Tandemloc, Inc. Disclosure, or copying without the written authorization of Tandemloc, Inc. is expressly prohibited. © Copyright 2010 by Tandemloc, Inc. Dimensions are subject to manufacturing tolerance and change.

| REVISIONS |                                | DATE    | APPROVED |
|-----------|--------------------------------|---------|----------|
| REV       | DESCRIPTION                    |         |          |
| A         | WLL 10,000 LB WAS WLL 6,000 LB | 2/01/10 | DAH      |



Email: [info@tandemloc.com](mailto:info@tandemloc.com) • [www.tandemloc.com](http://www.tandemloc.com)  
 PO Box 279 • 824 Highway 101 • Havelock, NC 28532-0279  
 TEL: 1.800.258.7324 (252.447.7155)  
 FAX: 1.800.892.3273 (252.447.5502)

Tandemloc designs, manufactures and tests lifting, securing and mobilizing components for all industries. See our website for details and important safety information.

Tandemloc is a member of:

