

FOUR POINT ADJUSTABLE SPREADER (AA60000A-3PA)

Cage Code: 65059 | Drawing No: SAA60000A | Revision: A | Sheet: 1 of 1

UNLESS OTHERWISE SPECIFIED, DIMENSIONS ARE IN INCHES
SEE ELECTRONIC PARTS LIST FOR BILL OF MATERIALS

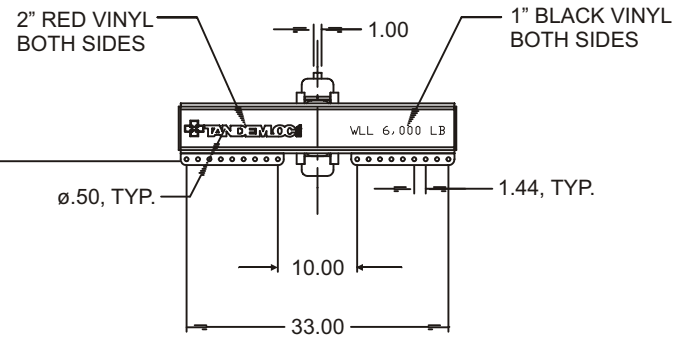
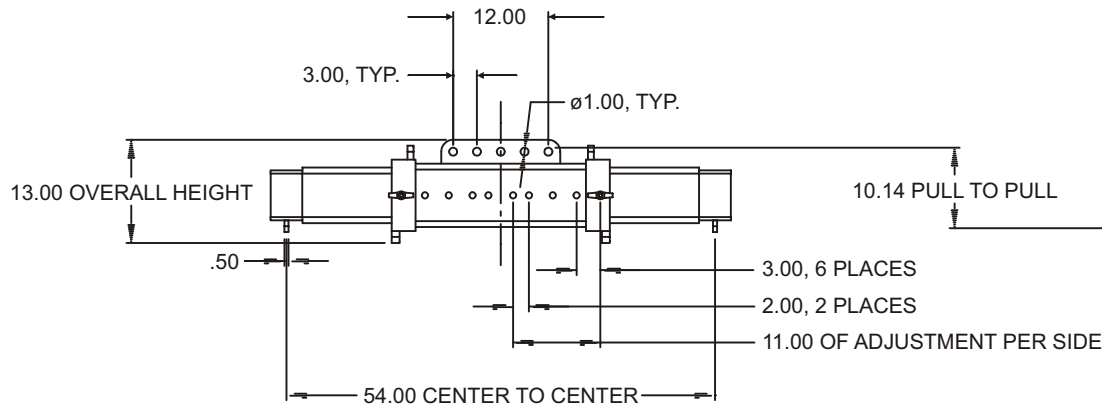
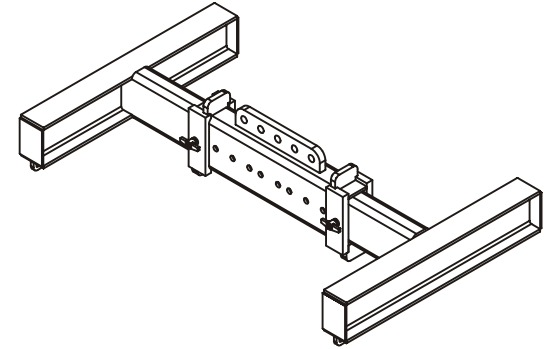
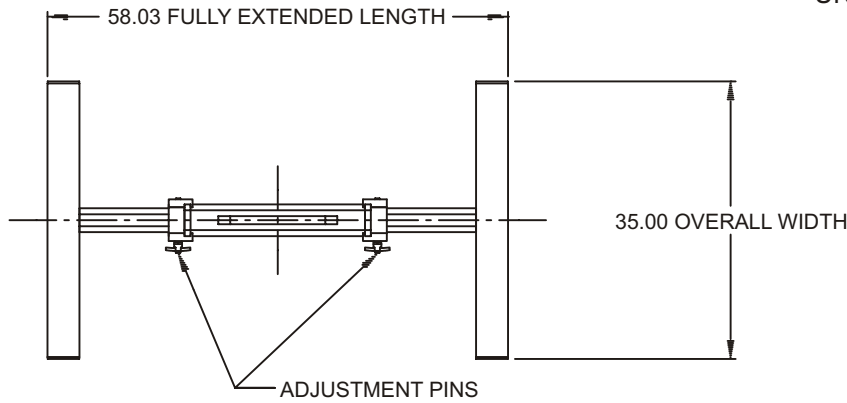

NOTES:

1. P/N: AA60000A-3PA
2. WLL: 6,000 LB.
3. PROOF TESTED TO 125% (7,500 LB.) AND CERTIFIED
4. STANDARD SPECIFICATION #EAD21000A APPLIES
5. FINISH: SANDBLAST, PRIME AND PAINT SAFETY YELLOW
6. CALCULATED WEIGHT: 292 LB
7. DESIGNED AND MANUFACTURED TO MEET OR EXCEED ASME B30.20 AND BTH1, DESIGN CATEGORY B, SERVICE CLASS 0

DANGER: Never Exceed WLL (Working Load Limit)

This document contains data which is either patented, patent pending or is the property of Tandemloc, Inc. Disclosure, or copying without the written authorization of Tandemloc, Inc. is expressly prohibited. © Copyright 2010 by Tandemloc, Inc. Dimensions are subject to manufacturing tolerance and change.

REVISIONS

REV	DESCRIPTION	DATE	APPROVED
A	ADDED SIDE PLATES TO CENTER TUBE, CHANGED PIN DESIGN, AND 292 LB. WAS 258 LB.	10/13/09	W.D.D.



Email: info@tandemloc.com • www.tandemloc.com
 PO Box 279 • 824 Highway 101 • Havelock, NC 28532-0279
 TEL: 1.800.258.7324 (252.447.7155)
 FAX: 1.800.892.3273 (252.447.5502)

Tandemloc designs, manufactures and tests lifting, securing and mobilizing components for all industries. See our website for details and important safety information.

Tandemloc is a member of:

