

REV	DESCRIPTION	REVISIONS	DATE	APPROVED
A	90.00 WAS 84.00, WLL WAS 32,000		05/05/06	BT

ADJUSTABLE LIFTBEAM (S41000F-1PA)

Cage Code: 65059 | Drawing No: SS41000F | Revision: A | Sheet: 1 of 1

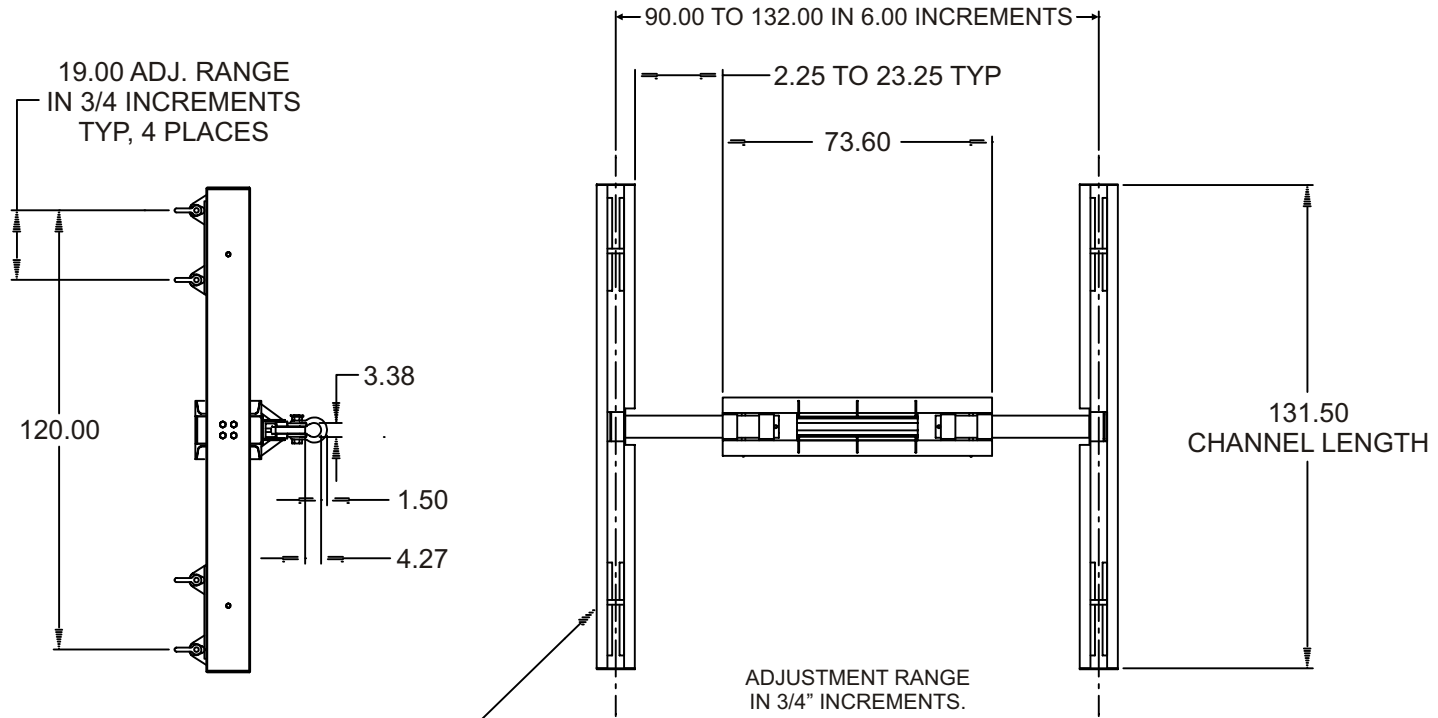

CHANNELS ARE 50KSI STEEL

NOTE:

1. P/N: S41000F-1PA, LIFTBEAM WITH ADJUSTABLE SLIDING PADEYES
2. WLL: 40,000 LB
3. PROOF TESTED TO 125% (50,000 LB) AND CERTIFIED
4. CONFORMS TO ASTM ANSI B30.20
5. FINISH: SANDBLAST, PRIME AND PAINT SAFETY ORANGE
6. CALCULATED WEIGHT: 2,700 LB

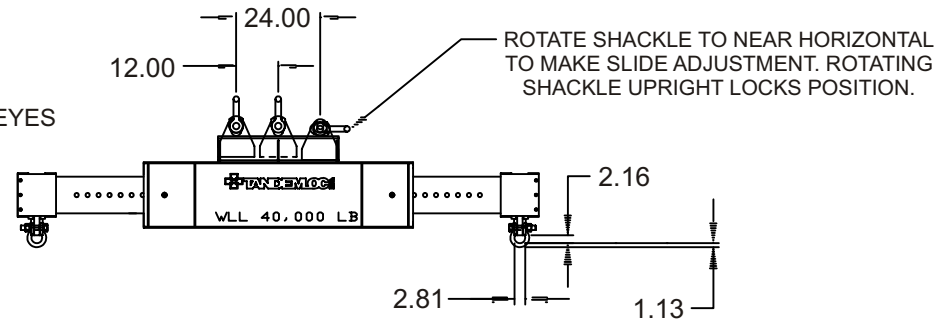

To avoid lifter failure, potential death and property damage, never exceed WLL (Working Load Limit)

This document contains the proprietary information of Tandemloc, Inc. and your access and use shall be, and is at all times, pursuant to and limited by the Tandemloc, Inc. Terms of Use.

You shall not, and shall not encourage, assist, or authorize another party to copy, distribute, publically display, modify, reverse engineer, decompile, or take any other action to reproduce or replicate this document or the information contained herein. © Copyright 2012 by Tandemloc, Inc.

Dimensions are subject to manufacturing tolerance and change.



Email: info@tandemloc.com • www.tandemloc.com
 824 Highway 101 • Havelock, NC 28532
 TEL: 1.800.258.7324 (252.447.7155)
 FAX: 1.800.892.3273 (252.447.5502)

Tandemloc designs, manufactures and tests lifting, securing and mobilizing components for all industries. See our website for details and important safety information.
 Read all safety labels and instructions prior to use. Product to be used by qualified personnel only.