

LIGHTWEIGHT FIXED FORK PALLET LIFTER (AN17A)

Cage Code: 65059 | Drawing No: SAN17A | Revision: -- | Sheet: 1 of 3

UNLESS OTHERWISE SPECIFIED, DIMENSIONS ARE IN INCHES
SEE ELECTRONIC PARTS LIST OF BILL OF MATERIALS
DO NOT SCALE DRAWING

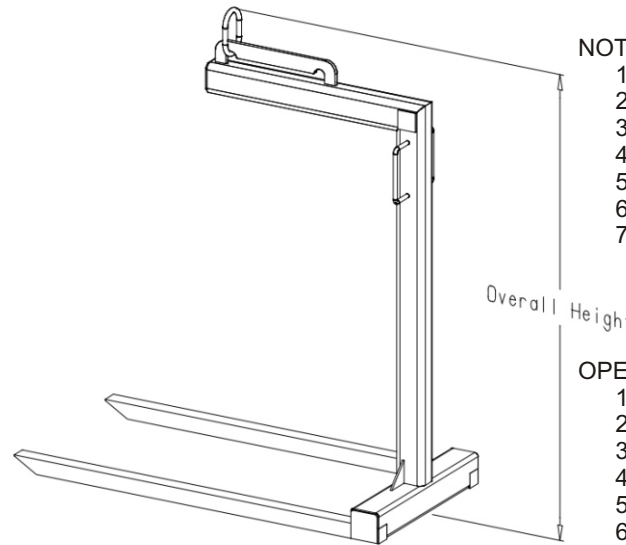
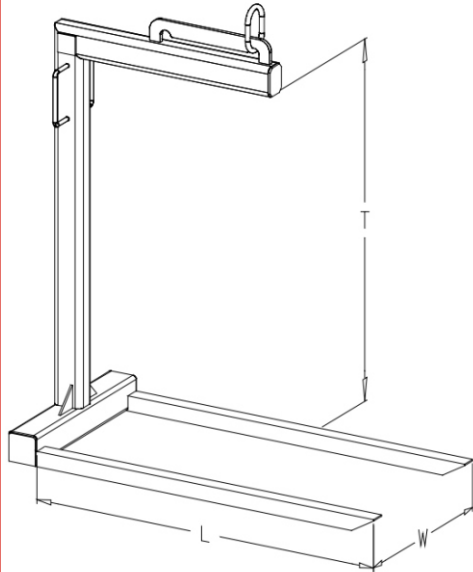

NOTES:

1. P/N: AN17AXX-00A-PA
2. WLL: SEE TABLE
3. PROOF TESTED TO 125% OF WLL
4. STANDARD SPECIFICATION #EAD21000A APPLIES
5. FINISH: SANDBLAST, PRIME AND PAINT SAFETY YELLOW
6. ESTIMATED UNIT WEIGHT : SEE TABLE
7. DESIGNED AND MANUFACTURED TO MEET OR EXCEED ASME B30.20 AND BTH-1, DESIGN CATEGORY B, SERVICE CLASS 0

OPERATIONAL NOTES:

1. Inspect lifter for damage before using
2. Never lift load greater than WLL
3. Rear hook location for unloaded movement
4. Forward hook location for loaded condition
5. Load CG should be vertically in-line with front hook location
6. Verify level lift with test lift of less than 6" above floor
7. Do not lift over people

Model	Capacity (lbs.)	Master Link Opening (in.)			Outside Fork Width (W)(in.)	Throat* (T) (in.)	Fork Length (L) (in.)	Fork Width (Fork W)(in.)	Fork Height (H)	Weight (lbs.)
AN17A02	2000	0.5	2.5	5.0	24.5	47.5	48	2	2	274
AN17A03	3000	0.5	2.5	5.0	25.0	47.5	48	3	2	316
AN17A04	4000	0.5	2.5	5.0	26.5	47.5	48	4	2	420
AN17A06	6000	0.5	2.5	5.0	26.5	47.5	48	4	2.5	515

To avoid lifter failure, potential death and property damage, never exceed WLL (Working Load Limit)

This document contains the proprietary information of Tandemloc, Inc. and your access and use shall be, and is at all times, pursuant to and limited by the Tandemloc, Inc. Terms of Use.

You shall not, and shall not encourage, assist, or authorize another party to copy, distribute, publically display, modify, reverse engineer, decompile, or take any other action to reproduce or replicate this document or the information contained herein. © Copyright 2012 by Tandemloc, Inc.

Dimensions are subject to manufacturing tolerance and change.



Email: info@tandemloc.com • www.tandemloc.com
824 Highway 101 • Havelock, NC 28532
TEL: 1.800.258.7324 (252.447.7155)
FAX: 1.800.892.3273 (252.447.5502)

Tandemloc designs, manufactures and tests lifting, securing and mobilizing components for all industries. See our website for details and important safety information.
Read all safety labels and instructions prior to use. Product to be used by qualified personnel only.

LIGHTWEIGHT WHEELED FIXED FORK PALLET LIFTER (AN17W)

Cage Code: 65059 | Drawing No: SAN17W | Revision: -- | Sheet: 2 of 3

UNLESS OTHERWISE SPECIFIED, DIMENSIONS ARE IN INCHES
SEE ELECTRONIC PARTS LIST OF BILL OF MATERIALS
DO NOT SCALE DRAWING

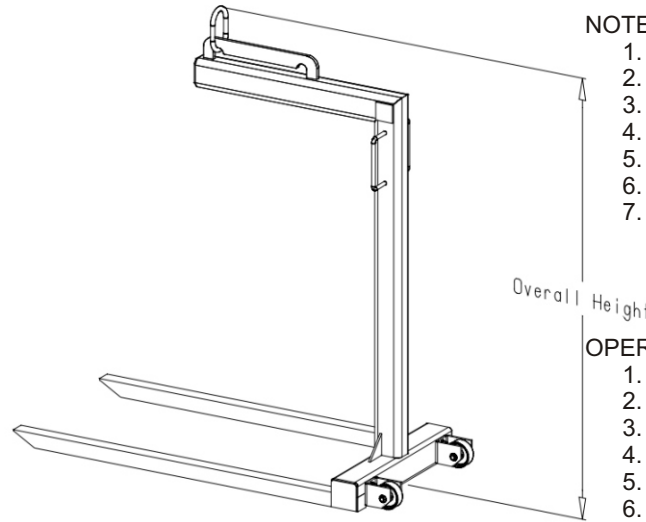
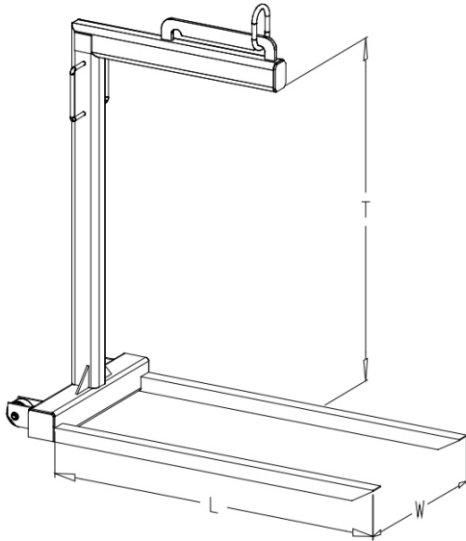

NOTES:

1. P/N: AN17WXX-00A-PA
2. WLL: SEE TABLE
3. PROOF TESTED TO 125% OF WLL
4. STANDARD SPECIFICATION #EAD21000A APPLIES
5. FINISH: SANDBLAST, PRIME AND PAINT SAFETY YELLOW
6. ESTIMATED UNIT WEIGHT : SEE TABLE
7. DESIGNED AND MANUFACTURED TO MEET OR EXCEED ASME B30.20 AND BTH-1, DESIGN CATEGORY B, SERVICE CLASS 0

OPERATIONAL NOTES:

1. Inspect lifter for damage before using
2. Never lift load greater than WLL
3. Rear hook location for unloaded movement
4. Forward hook location for loaded condition
5. Load CG should be vertically in-line with front hook location
6. Verify level lift with test lift of less than 6" above floor
7. Do not lift over people

Model	Capacity (lbs.)	Master Link Opening (in.)			Outside Fork Width (W)(in.)	Throat* (T) (in.)	Fork Length (L) (in.)	Fork Width (Fork W)(in.)	Fork Height (H)	Weight (lbs.)
AN17W02	2000	0.5	2.5	5.0	24.5	47.5	48	2	2	289
AN17W03	3000	0.5	2.5	5.0	25.0	47.5	48	3	2	331
AN17W04	4000	0.5	2.5	5.0	26.5	47.5	48	4	2	435

To avoid lifter failure, potential death and property damage, never exceed WLL (Working Load Limit)

This document contains the proprietary information of Tandemloc, Inc. and your access and use shall be, and is at all times, pursuant to and limited by the Tandemloc, Inc. Terms of Use.

You shall not, and shall not encourage, assist, or authorize another party to copy, distribute, publically display, modify, reverse engineer, decompile, or take any other action to reproduce or replicate this document or the information contained herein. © Copyright 2012 by Tandemloc, Inc.

Dimensions are subject to manufacturing tolerance and change.



Email: info@tandemloc.com • www.tandemloc.com
824 Highway 101 • Havelock, NC 28532
TEL: 1.800.258.7324 (252.447.7155)
FAX: 1.800.892.3273 (252.447.5502)

Tandemloc designs, manufactures and tests lifting, securing and mobilizing components for all industries. See our website for details and important safety information.
Read all safety labels and instructions prior to use. Product to be used by qualified personnel only.

FIXED FORK PALLET LIFTER (AN18A)

Cage Code: 65059 | Drawing No: SAN18A | Revision: -- | Sheet: 3 of 3

UNLESS OTHERWISE SPECIFIED, DIMENSIONS ARE IN INCHES
SEE ELECTRONIC PARTS LIST OF BILL OF MATERIALS
DO NOT SCALE DRAWING

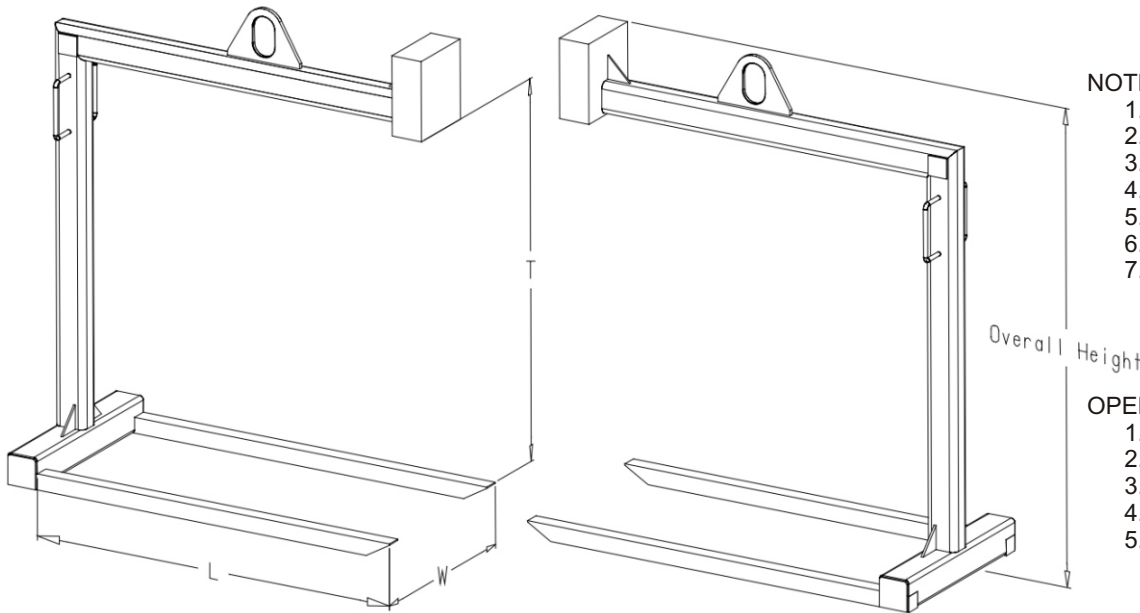

NOTES:

1. P/N: AN18AXX-00A-PA
2. WLL: SEE TABLE
3. PROOF TESTED TO 125% OF WLL
4. STANDARD SPECIFICATION #EAD21000A APPLIES
5. FINISH: SANDBLAST, PRIME AND PAINT SAFETY YELLOW
6. ESTIMATED UNIT WEIGHT : SEE TABLE
7. DESIGNED AND MANUFACTURED TO MEET OR EXCEED ASME B30.20 AND BTH-1, DESIGN CATEGORY B, SERVICE CLASS 0

OPERATIONAL NOTES:

1. Inspect lifter for damage before using
2. Never lift load greater than WLL
3. Load CG should be vertically in-line with hook location
4. Verify level lift with test lift of less than 6" above floor
5. Do not lift over people

Model	Capacity (lbs.)	Lifting Hook Opening (in.)			Outside Fork Width (W)(in.)	Throat* (T) (in.)	Fork Length (L) (in.)	Fork Width (Fork W)(in.)	Fork Height (H)	Weight (lbs.)
AN18A02	2000	0.5	3.0	5.0	24.5	47.5	48	2	2	352
AN18A03	3000	0.5	3.0	5.0	25.0	47.5	48	2	3	463
AN18A04	4000	0.5	3.0	5.0	26.5	47.5	48	2	4	597
AN18A06	6000	0.5	3.0	5.0	26.5	47.5	48	2.5	4	791

To avoid lifter failure, potential death and property damage, never exceed WLL (Working Load Limit)

This document contains the proprietary information of Tandemloc, Inc. and your access and use shall be, and is at all times, pursuant to and limited by the Tandemloc, Inc. Terms of Use.

You shall not, and shall not encourage, assist, or authorize another party to copy, distribute, publically display, modify, reverse engineer, decompile, or take any other action to reproduce or replicate this document or the information contained herein. © Copyright 2012 by Tandemloc, Inc.

Dimensions are subject to manufacturing tolerance and change.



Email: info@tandemloc.com • www.tandemloc.com
824 Highway 101 • Havelock, NC 28532
TEL: 1.800.258.7324 (252.447.7155)
FAX: 1.800.892.3273 (252.447.5502)

Tandemloc designs, manufactures and tests lifting, securing and mobilizing components for all industries. See our website for details and important safety information.

Read all safety labels and instructions prior to use. Product to be used by qualified personnel only.