

# SPREADER BAR LIFTERS FOR 20 AND 40 FOOT ISO CONTAINERS (AK24/25A00-00A-PA)

Cage Code: 65059 | Drawing No: DAK24-25A00 | Revision: -- | Sheet: 1 of 1

UNLESS OTHERWISE SPECIFIED, DIMENSIONS ARE IN INCHES  
DO NOT SCALE DRAWING

**NOTES:**

- GENERAL - ALL CONTAINERS, CORNER FITTINGS AND SLING EQUIPMENT SHALL BE INSPECTED FOR FLAWS AND DAMAGE BEFORE USE. ONLY EQUIPMENT IN GOOD CONDITION SHALL BE LIFTED.
- IN SOME CASES, I.S.O. CONTAINER MEASURED LENGTHS DIFFER FROM SIZE "L". REF. I.S.O. STD. 668.
- 20'/40' COMBO SLINGS HAVE SHORT WIRE ROPE LEGS FOR A 20' LIFT & FOUR WIRE ROPE EXTENSIONS FOR A 40' LIFT.
- MATERIAL AND FINISH:  
PC1 - STEEL, PAINTED  
PC2 - STEEL, BRIGHT  
PC3 - STEEL, PAINTED
- ALL VERTICAL DIMENSIONS ARE SUBJECT TO SIGNIFICANT VARIATION DUE TO THE ACCUMULATION OF TOLERANCES FOR THE HEAVY WIRE ROPE LENGTHS. IF THE VERTICAL DIMENSION IS IMPORTANT IN YOUR APPLICATION, ASK FOR A WIRE ROPE SLING WITH SHACKLE AND ADJUSTING TURNBUCKLE FOR FINITE ADJUSTMENT.
- DIMENSIONS NOTED ARE FOR REFERENCE ONLY AND ARE SUBJECT TO MFG. TOLERANCE.
- SLING ASSEMBLIES MEET ISO 3874, ANSI/ASME B30.20
- PROOF TESTED TO 125% OF RATED WORK LOAD.

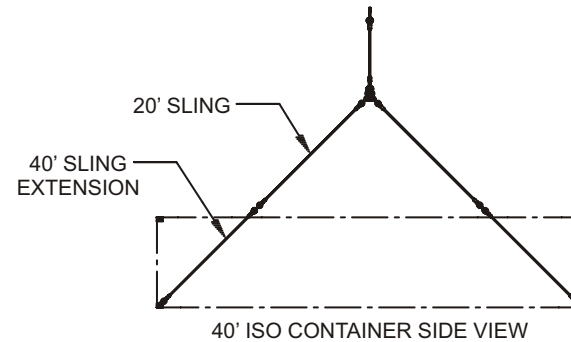
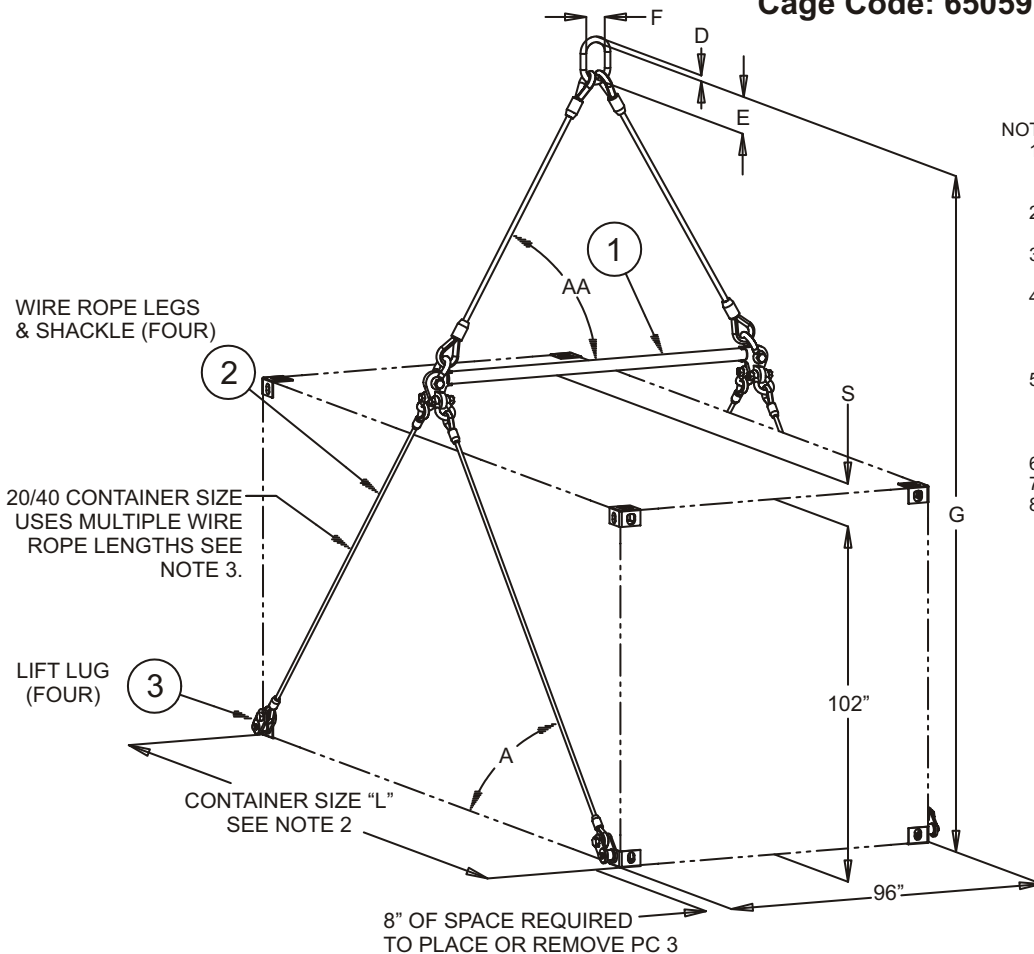

"L" CONTAINER SIZE	RATED WORK LOAD	ORDER NUMBER	"S" SLACK	TOTAL WEIGHT	"AA" USE ANGLE	"A" USE ANGLE	"D" MASTER RING DIAMETER	"E" MASTER RING HEIGHT	"F" MASTER RING WIDTH	"G" - MASTER RING TO CONT. BOTTOM	COMPONENT PART NUMBERS		
											PC1 - LIFT BEAM	PC2 - WIRE ROPE LEGS & SHACKLE	PC3 - LIFT LUG
20'	52,900 LB.	AK24A00-00A-PA	17"	509 LB.	60°	45°	1.61"	10.50"	5.90"	214"	AK24A01-00A-PA	AK24A03-00A	416000C-LSTZ
20'	67,200 LB.	AK25A00-00A-PA	17"	667 LB.	60°	45°	1.75"	12.00"	6.00"	216"	AK25A01-00A-PA	AK25A03-00A	416000C-LSTZ
40'/20'	67,200 LB.	AK25A00-01A-PA	138"	812 LB.	60°	45°	1.75"	12.00"	6.00"	336"	AK25A01-00A-PA	AK25A03-00A/AK25A04-00A	416000C-LSTZ

To avoid lifter failure, potential death and property damage, never exceed WLL (Working Load Limit)

This document contains the proprietary information of Tandemloc, Inc. and your access and use shall be, and is at all times, pursuant to and limited by the Tandemloc, Inc. Terms of Use.

You shall not, and shall not encourage, assist, or authorize another party to copy, distribute, publically display, modify, reverse engineer, decompile, or take any other action to reproduce or replicate this document or the information contained herein. © Copyright 2012 by Tandemloc, Inc.

Dimensions are subject to manufacturing tolerance and change.



Email: [info@tandemloc.com](mailto:info@tandemloc.com) • [www.tandemloc.com](http://www.tandemloc.com)  
824 Highway 101 • Havelock, NC 28532  
TEL: 1.800.258.7324 (252.447.7155)  
FAX: 1.800.892.3273 (252.447.5502)

Tandemloc designs, manufactures and tests lifting, securing and mobilizing components for all industries. See our website for details and important safety information.  
Read all safety labels and instructions prior to use. Product to be used by qualified personnel only.