

D-RING & STRAP TYPE 304 STAINLESS STEEL

Cage Code: 65059 | Drawing No: SAJ10A00 | Revision: - | Sheet: 1 of 1

UNLESS OTHERWISE SPECIFIED, DIMENSIONS ARE IN INCHES
DO NOT SCALE DRAWING

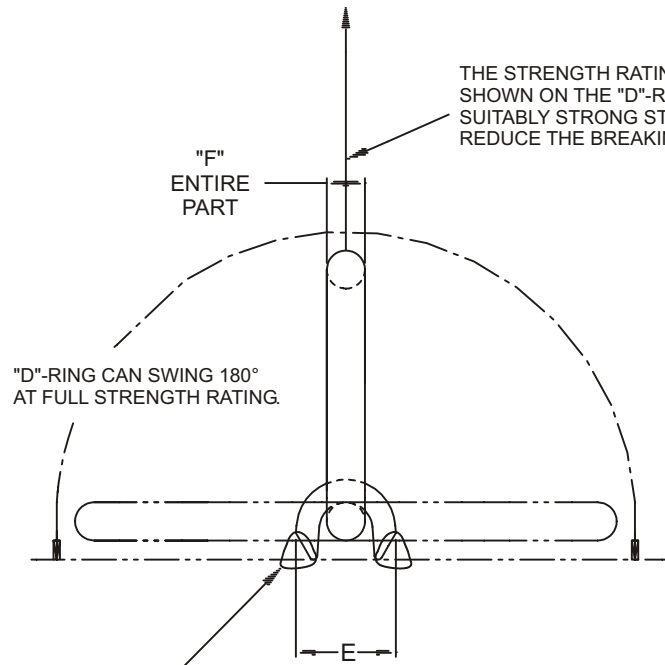

THE STRENGTH RATINGS ARE BASED ON THE LOAD DIRECTION SHOWN ON THE "D"-RING WITH THE STRAP WELDED TO A SUITABLY STRONG STRUCTURE. OTHER LOAD ANGLES WILL REDUCE THE BREAKING STRENGTH RATING. (SEE NOTE 1)

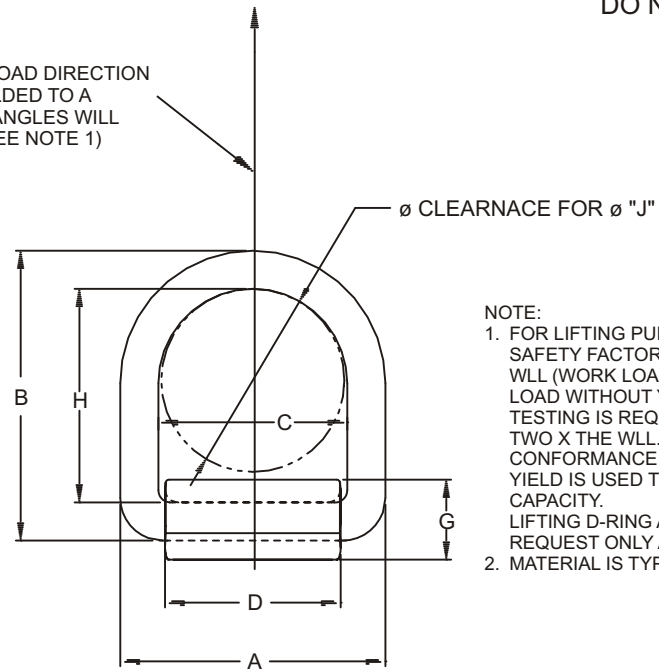

- NOTE:
- FOR LIFTING PURPOSES, WHERE A 3:1 SAFETY FACTOR TO YIELD IS REQUIRED, THE WLL (WORK LOAD LIMIT) IS 1/3 OF THE MAX. LOAD WITHOUT YIELD. WHEN PROOF TESTING IS REQUIRED, THE PROOF TEST IS TWO X THE WLL. FOR MIL STD 209H CONFORMANCE, THE MAX LOAD WITHOUT YIELD IS USED TO DETERMINE THE USE CAPACITY. LIFTING D-RING AND STRAPS ARE BY REQUEST ONLY AND HAVE ADDITIONAL COST.
 - MATERIAL IS TYPE 304 STAINLESS STEEL.

WELD TYPE 304 STAINLESS STEEL STRAP TO SUITABLE STRUCTURE WITH "K" SIZE FILLET WELDS. WELD AROUND EDGES. AVOID HEATING THE D-RING EXCESSIVELY.

"D"-RING & STRAP P/N	"D"-RING ONLY P/N	STRAP ONLY P/N	MAX LOAD WITHOUT YIELD STRAIGHT TENSION	AVERAGE ULTIMATE STRENGTH	WEIGHT		DIMENSIONS (INCHES)										MIN WELD SIZE
					"D"-RING	STRAP	A	B	C	D	E	F	G	H	ØJ	K	
AJ10A00-DS07	AJ10A00-D07	AJ10A00-S07	4,800	7,100	1.3	.76	4.34	4.75	3.09	2.88	1.65	.63	1.31	3.50	3.00	.38	
-	-	-	-	-	-	-	-	-	-	-	-	-	-	-	-	-	
-	-	-	-	-	-	-	-	-	-	-	-	-	-	-	-	-	
-	-	-	-	-	-	-	-	-	-	-	-	-	-	-	-	-	
-	-	-	-	-	-	-	-	-	-	-	-	-	-	-	-	-	

To avoid lifter failure, potential death and property damage, never exceed WLL (Working Load Limit)

This document contains the proprietary information of Tandemloc, Inc. and your access and use shall be, and is at all times, pursuant to and limited by the Tandemloc, Inc. Terms of Use.

You shall not, and shall not encourage, assist, or authorize another party to copy, distribute, publically display, modify, reverse engineer, decompile, or take any other action to reproduce or replicate this document or the information contained herein. © Copyright 2012 by Tandemloc, Inc.

Dimensions are subject to manufacturing tolerance and change.



Email: info@tandemloc.com • www.tandemloc.com
 824 Highway 101 • Havelock, NC 28532
 TEL: 1.800.258.7324 (252.447.7155)
 FAX: 1.800.892.3273 (252.447.5502)

Tandemloc designs, manufactures and tests lifting, securing and mobilizing components for all industries. See our website for details and important safety information.
 Read all safety labels and instructions prior to use. Product to be used by qualified personnel only.