

# SPREADER, 2 CRANE BOTTOM LIFT (AF11A00-00A-PA)

Cage Code: 65059 | Drawing No: SAF11A00-00A-PA | Revision: D | Sheet: 1 of 1

UNLESS OTHERWISE SPECIFIED, DIMENSIONS ARE IN INCHES  
SEE ELECTRONIC PARTS LIST FOR BILL OF MATERIALS  
DO NOT SCALE DRAWING

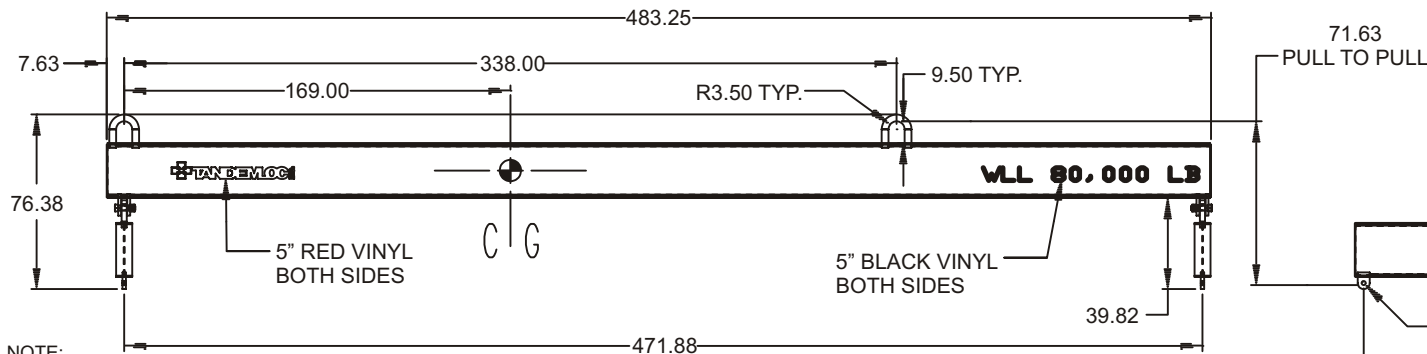
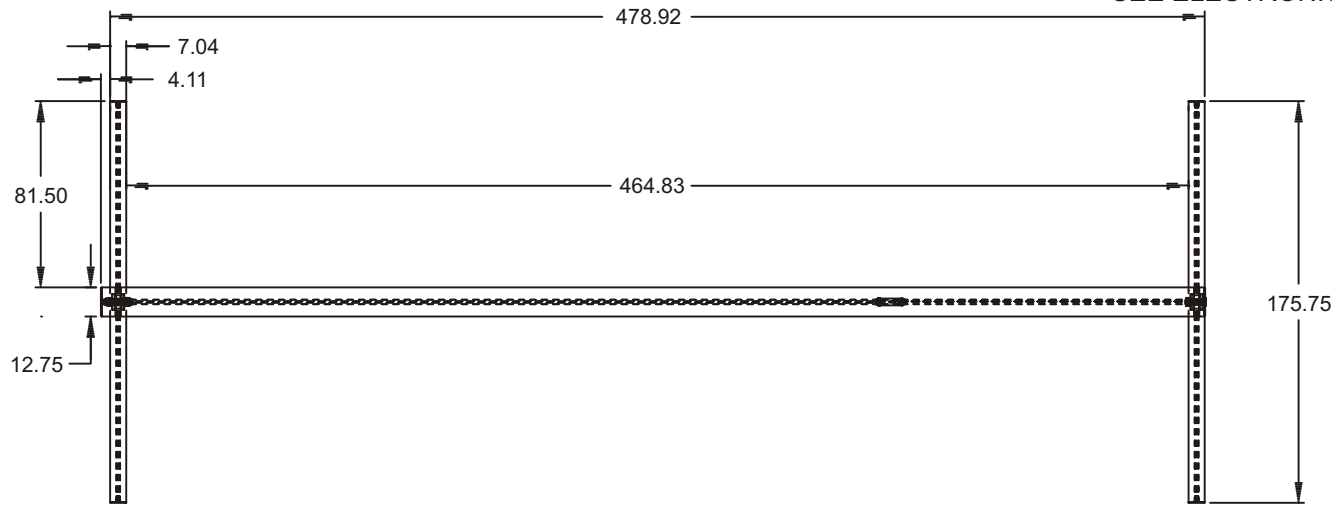

- NOTE:
1. P/N: AF11A00-00A-PA, SPREADER, 2 CRANE BOTTOM LIFT
  2. WLL: 40 TONS (80,000 LBS)
  3. PROOF TESTED TO 125% (100,000 LB) AND CERTIFIED
  4. STANDARD SPECIFICATION #EAD2100A APPLIES
  5. FINISH: SANDBLAST, PRIME AND PAINT SAFETY YELLOW
  6. CALCULATED WEIGHT: 6,500 LBS

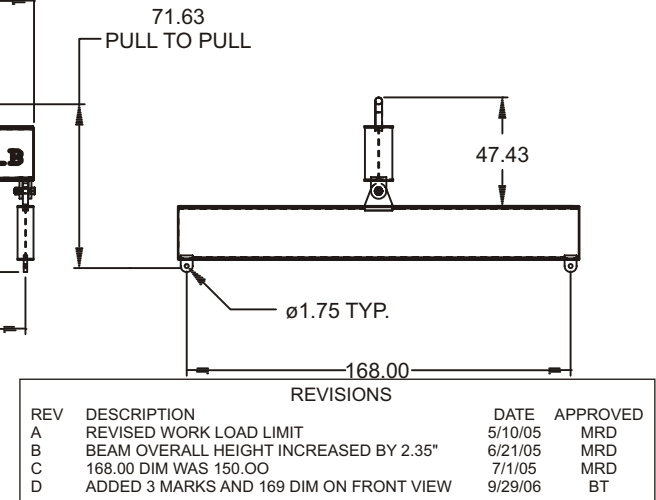

To avoid lifter failure, potential death and property damage, never exceed WLL (Working Load Limit)

This document contains the proprietary information of Tandemloc, Inc. and your access and use shall be, and is at all times, pursuant to and limited by the Tandemloc, Inc. Terms of Use.

You shall not, and shall not encourage, assist, or authorize another party to copy, distribute, publically display, modify, reverse engineer, decompile, or take any other action to reproduce or replicate this document or the information contained herein. © Copyright 2012 by Tandemloc, Inc.

Dimensions are subject to manufacturing tolerance and change.



Email: [info@tandemloc.com](mailto:info@tandemloc.com) • [www.tandemloc.com](http://www.tandemloc.com)  
824 Highway 101 • Havelock, NC 28532  
TEL: 1.800.258.7324 (252.447.7155)  
FAX: 1.800.892.3273 (252.447.5502)

Tandemloc designs, manufactures and tests lifting, securing and mobilizing components for all industries. See our website for details and important safety information.  
Read all safety labels and instructions prior to use. Product to be used by qualified personnel only.